

Switchboard Arrangement for Small Strata Lot Developments. Guideline – 02

1. Brief description

This interim Guideline has been prepared to assist consumers, industry and Western Power personnel, assess, determine and consistently apply regulatory and network requirements pertaining to the provision of network and consumer electrical infrastructure applicable to Small Strata (up to and include 4 lots) developments.

1.1 Related policies

This interim Guideline is made under and supports the Underground Distribution Schemes Manual (UDS) and Western Australian Distribution Connections Manual (WADCM). In addition to the UDS and the WADCM, this Guideline is to be read in conjunction with the:

- Applicable Australian Standards inclusive of but not limited to AS/NZS 3000-2018 and 4777-2016;
- Department of Planning Model Conditions (Consumer and Industry stakeholders);
- Application of Model Conditions (Network stakeholders);
- Overhead to Underground Conversion Standard (Previously known as Pole to Pillar - P2P);
- Network Integration Guideline (NIG) for Inverter Embedded Generation;
- WA Electrical Requirements (WAER) 2014 as amended.

1.2 Introduction

Where there is an intent to subdivide either a new or existing parcel of land, appropriate network and private electricity infrastructure is required to be installed prior to the creation of property titles.

The UDS sets out the minimum network and private requirements for all Subdivision distribution schemes that are or have the potential to either import or export electricity from and/or to Western Power's Distribution Network. The WADCM prescribes the methodology and conditions to be applied when connecting consumers to that combined distribution infrastructure.

Both the WADCM and NIG document further define the minimum capacity requirements for both "Standard Supply" and "Hosting Capacity".

In summary a combined network/private distribution scheme must be able to:

- Accommodate energy import/export capacities measured at each network meter for:
 - **Single-phase:**
 - Import capacity of 63 amps (Metropolitan and major regional centres); or 32 amps (Rural areas);
 - Export capacity of 5 kVA (Rural connections subject to network capacity evaluation)
 - **Three-phase:**
 - Import capacity 32 amps per phase, three phase, for multi-phase (SWIS);
 - Export capacity of 8 kVA.
- Maintain a voltage range of 240 volt single phase (+/- 6%) or 415 volt three phase (+/- 6%) measured at the point of connection/supply over a 5 min average;
- Accept consumer mains/submain main cable connections not exceed 35 mm² to the network meter.

1.3 Purpose

The purpose of this Guideline is to ensure, the consistent application of Subdivision and Connection Requirements for small Strata Subdivisions as prescribed by the UDS and the WADCM.

1.4 Scope

This Guideline applies to the electricity Distribution Network within Western Power's South West Interconnected System (SWIS) where a new or existing parcel of land is to be subdivided, amalgamated or have property boundaries realigned, resulting in the creation or confirmation of one or more strata lots not exceeding four lots within that parcel of land.

Compliance with this Guideline is mandatory.

This Guideline does not apply to freehold title Subdivisions, amalgamations or boundary realignments (Refer to the UDS manual for requirements).

1.5 Application and Publication

The content of this document aligns with current Western Power Subdivision and Connection Requirements.

Application of these requirements shall be applied to all current and new strata Subdivision projects prior to and from the Date of Publication.

2. Details

2.1 UDS Requirements

Clause 2.2.1 Electrical reticulation in part states

These requirements apply to Western Power's electrical reticulation servicing freehold subdivisions and private distribution systems servicing survey strata lots and common property.

Underground electricity reticulation is mandatory in all new freehold and survey strata subdivisions with lot sizes up to 10 hectares and applies to all subdivisions, including residential, rural residential, commercial and industrial.

Clause 2.2.3.4 (e) Service connections in survey strata subdivisions in part states:

Where survey strata lots or built strata lots are created on a freehold lot, a main switchboard (MSB), suitable for supplying all of the strata lots, shall be established at the point of connection/supply.

Note: As of the 1st February 2020 the requirement to supply and install a MSB is applicable for all survey and built strata developments. Direct connections from strata lots, created after that date, to the network will not be permitted after 1st July 2020.

Clause 4.1.4.1 (e) Small Subdivisions in part states:

Overhead network and connection services are converted underground.

Clause 4.1.5.1 Requirements in part states:

WAPC conditions on approved subdivision plans for both freehold and survey strata developments are only cleared after the following requirements are met:

a) Payment in full of Western Power quote including where appropriate a Per-Lot Fee (Refer Clause 3.9) and

b) Submission of a copy of the deposited and or survey strata plan of the subdivision to Western Power showing substation sites, easement, restrictive covenant and Notification requirements, and

c) Compliance with other easement and/or special requirements that may include provision of Main Switchboards and Completion Notices for survey strata developments; and

Either,

d) Western Power receipt of As Constructed drawings for large projects

Or,

e) For early clearance request a copy of Approved for Construction drawing being part of the DCR submission and compliance with Early Clearance requirements of Clause 3.9.

Note: The underground conversion and connection of any existing services within the subdivision to the installed MSB is an essential condition for title clearance.

2.2 WADCM Requirements

Clause 11.5.1 General in part states:

Unless specified otherwise by these requirements or the Network Operator, network service and metering equipment (metering equipment) shall be located:

a) not be more than 30 metres (route length) from the point of supply where the consumer mains cable is electrically unprotected; and

b) on the principal frontage of the premises (but not more than 1 metre down any side wall) facing a road, laneway or access way that has been gazetted or classified as the official address for that building or premises.

Note: MSB to be located in accordance with applicable Industry Standards and the WADCM.

Clause 11.11.2 Installation requirements (Multiple master metering) in part states:

Where the units are for domestic use, they shall be self-contained with facilities for maintenance and fault finding incorporated into the installation, to provide security of supply for each and every customer.

The site main switchboard/multiple master metering enclosure shall be installed in a common area not be more than 30 metres (consumer mains cable route length) from the point of supply.

The enclosure shall not be installed within the wall(s) of one or more of the individual units.

Clause 11.12.2 Installation requirements (Distributed master metering) in part states:

A distributed master metered installation shall have only one point of supply. The site main switchboard shall be located not more than 30 metres (consumer mains cable route length) from the point of supply.

Service and metering equipment shall be located in accordance with Clauses 11.5.1 and 11.5.2 in a position on the principal frontage as close as practical to the entry of each premise so that the metering equipment is readily identifiable and accessible. Where the installation cannot satisfy these requirements, refer to Clause 11.11 for meter location details.

Grouping of individual distributed master meters and their enclosures in either a single or multiple location(s) is not permitted (refer to Clause 11.11 Multiple Master Metering).

Clause 12.6.3 Voltage drop/rise in part states:

For the purposes of calculating voltage drop, the assessed component across the consumer's mains shall be calculated in accordance with AS/NZS 3000 and 3008 part 1. Refer to Clause 15.12 and 15.16 for further information on voltage rise.

Note: Network Integration Guideline Table 8: (IEG capacity evaluation limits at point of connection/supply) and WADCM clause 15.16.8.1 in part states that the voltage rise across the customer's electrical installation should not exceed 2% measured from the terminals of the IEG to the point of connection/supply. The NIG sets industry best practice at 1% of the rated voltage.

2.3 AS/NZS 3000:2018

Clause 1.6.3 **Maximum demand** in part states:

The maximum demand of an electrical installation shall be determined, taking account the capacity, physical distribution and intended use of electrical equipment in the electrical installation and the manner in which the present requirements might vary. Consumer mains, submains and other electrical equipment of an electrical installation shall be designed and installed to meet the maximum demand.

Clause 2.2.2 offers 4 options to determine an installations maximum demand.

Note: Where the maximum demand cannot be determined or managed then that demand shall be determined by limitation.

2.4 WA Planning Commission (WAPC) Model Condition requirements.

The WAPC determines the requirements for freehold, vacant and survey strata Subdivisions in WA with the exception of built strata Subdivisions which are generally determined by Local Government.

Model subdivision conditions are an essential tool used by the WAPC to ensure compliance with its statutory and policy responsibilities.

Model conditions applied at the time of a subdivision or connection application, provide a standardised set of tested and agreed conditions, for use by the Department of Planning, Lands and Heritage (the Department) in its role of supporting the WAPC. The State Planning Commission has the power to impose such conditions, consistent with the application of sound town planning principles. (*Hill v State Planning Commission* TPAT).

2.4.1 Clearance of condition

WAPC Model Conditions (E1 through E8 and Ea1) are used by Western Power as a referral (clearance) agency to formalise subdivision and connection advice to the Department of Planning.

Subdivision infrastructure and connections are required to be constructed in accordance with the approved Condition(s). On completion of the works the landowner/applicant is responsible for obtaining the 'clearance' from the agency (Western Power) prescribed with the responsibility for 'clearing' the relevant condition.

Once all conditions have been met by the landowner/applicant and appropriate clearances obtained, the applicant may then seek/request the endorsement of diagrams or plans of survey subdivision in accordance with Section 145 of the Planning and Development Act 2005 facilitating the creation of property titles.

Note: Western Power applies the same set subdivision/connection conditions and requirements for built strata developments.

3. Minimum requirements

In summary to ensure compliance with the applicable condition criteria for strata developments as identified above the following minimum elements need to be fulfilled:

- a. Provision of underground network electricity reticulation (e.g. service main and pillar) to the subdivision;
- b. Provision of underground private electricity reticulation (e.g. switchboard, protection devices, metering, consumer/sub mains, earthing system and associated infrastructure);
- c. A combined network and private arrangement that:
 - I. Facilitates the delivery of the required minimum energy import/export capacities to each lot (dwelling) within the development;
 - II. Complies with applicable legislation and industry standards for installation and voltage;
 - III. Complies with Western Power requirements, WAPC Model and/or Local Government conditions where applied;
- d. Redundant overhead customer equipment, infrastructure and poles has been removed or provision made and validated for the removal of same on completion of the conversion at the customer's cost;
- e. Any applicable site specific conditions inclusive of but not limited to:
 - I. Conversion and connection of any existing overhead service to the site MSB; and
 - II. Relocation and connection of any existing underground service to the site MSB.

4. Solution

The attached drawings and supportive notes provide an appropriate solution:

4.1 Drawing Notes

1. Drawings and notes shall be read in conjunction with applicable Legislation, Industry Standards, Codes, inclusive of but not limited to the:
 - a. AS/NZS 3000 and AS/NZS 4777;
 - b. WA Electrical Requirements (WAER);
 - c. Underground Distribution Schemes Manual (UDS);
 - d. WA Distribution Connections Manual (WADCM).

Note:

For strata developments and lot title clearance requirements refer to Western Power's WAPC terms and conditions.

2. For small subdivisions (up to 4) strata lots, the customer's point of connection/supply (POS) shall be the network nominated mini pillar as determined by Western Power.

Note:

- a. Network service and metering equipment(s) must be installed prior to the connection and energisation of the consumer mains cable to the network asset;
- b. Customer connections via a pit, wall box or to a large subdivision (5 or more) require Western Power approval before installation and or connection.

3. The connection/supply arrangement for the total development shall make provision for the delivery of a standard three (3) phase supply (as defined by the WADCM) to each individual lot (dwelling).

4. Maximum number (#) of standard supply/hosting capacity connections shall not exceed four (4) to the pillar.

Note:

- a. Each lot (dwelling) within the development is defined as a connection regardless of whether the connection is direct or via a MSB;
- b. In determining the number of connections to a pillar, all connections to or from adjacent lots (dwellings) shall be included;
- c. Where any individual consumer mains cable exceeds 30m (route length) all new and existing connections within the development shall be via a site main switch board (MSB) as defined in section 5 of this document.

5. The consumer main and submain cables shall be sized and installed in accordance with AS/NZS 3000; WAER, and the WADCM.

6. SPD denotes service protection device. The device shall grade with the upstream network protection.

Note:

- a. The fault rating of the SPD shall be as specified by the WAER, Technical Rules and the WADCM;
- b. The maximum current carrying of the device shall not exceed the rating of the network service main cable (Cat EE1425) which for a mini pillar is 125 amps;
- c. The SPD primary function is network protection and isolation;
- d. The device does not replace the installation main switch and shall not be deemed as protection for the customer's electrical installation, equipment, or consumer mains cable.

7. MPD denotes meter protection device. The device shall grade with the upstream network protection.

Note:

- a. The fault rating of the MPD shall be as specified by the Network operator and the WADCM;
- b. The maximum current carrying of the device shall not exceed the rating of the network meter which for whole of current metering is 80 amps;
- c. The MPD primary function is meter protection and isolation.
- d. The device does not replace the installation main switch and shall not be deemed as protection for the customer's electrical installation, equipment, or downstream circuitry.

8. MS denotes customer's main switch. The device shall function and grade in accordance with this Guideline, AS/NZS 3000, AS/NZS 4777 and the WADCM.

Note:

The MS for new, altered or augmented connection arrangements shall be:

- a. A circuit breaker which grades with the upstream protection;
- b. Fault rated in accordance with AS/NZS 3000, AS/NZS 4777 and the WADCM;
- c. Where require provide downstream protection in accordance with the appropriate industry standard;
- d. Rated in accordance with the:
 - I. Calculated Maximum Demand (CMD) or consumer mains cable whichever is the lessor: and
 - II. Where there are multiple mains switches the sum of the current ratings of the individual circuit-breakers shall not exceed the capacity of consumer mains cable or the SPD whichever is the lessor. (Refer to AS/NZS 3000 2018 clauses 2.5.1 and 2.5.1.2 for guidance.)

9. Maximum Total:

- a. Load (MTL) at the PCC shall not exceed the rating of the network service equipment and cable;
- b. Generation (MTG) (hosting capacity) \leq 30 % of network capacity at the PCC or as approved by Western Power.











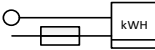
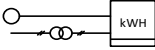
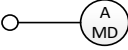

10. The illustrated earthing arrangement shall be in accordance with WAER, AS/NZS 3000 and the WADCM.

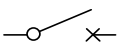
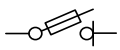
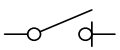
11. The network metering arrangement shall be in accordance with the Metering Code 2012 and the WADCM.

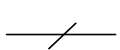
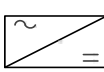
12. Customer protection devices shown for illustration purposes only.

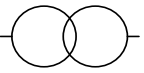
13. The configuration of consumer main and submain cables, is dependent on the customer's connection requirement. The final connection to the individual lot (dwelling) may be single or three phase.

4.2 Drawings

	Whole Current (direct connected) Meter (non CT)		
	LV Current Transformer Meter (LV CT)		
	HV Current Transformer Metering Unit (HV CT)		
	Maximum Demand Meter		
	Links (Removable)		
	Connection Block		
	Fuse		
	Circuit Breaker (CB)		
	Combination Fuse Switch		
	LV Links or HV / LV load Disconnect		
	Drop Out Fuse (DOF)		
	Pole Top Switch		
	Inverter		
	Battery		
	Generator		
	Transformer (Tx)		
	Cable Termination to Network Assets Including Switchgear or Transformer		
	Cable Termination to Overhead Network		
CB	Circuit Breaker	MPD	Meter Protection Device (Meter Fuse)
CFS	Combination Fuse / Switch	MCB	Mains Connection Box
CP	Connection Point	MPS	Modular Package Substation
CMS	Customer Main Switch	MSB	Main Switchboard
CPS	Customer Paralleling Switch	MS	Main Switch
CPR	Customer Protection Relay	MTG	Maximum Total Generation
CT	Current Transformer	MTL	Maximum Total Load
DB	Customer Distribution Board		Neutral Conductor
	Earth Connection	NOP	Normally Open Point
FSD	Fuse Switch Disconnect	PoS	Point of Connection/Supply
GMS	Generator Main Switch	PCC	Point of Common Coupling
HV	High Voltage	SMSB	Site Main Switch Board
LU xx	Distribution Design Catalogue Reference	SPD	Service Protection Device

Drawings to be read in conjunction with applicable Legislation, Industry Standards, Codes, the WAER and WADCM

 westernpower Distribution Customer Connection Requirements EDM 435 17 326	Legend	Date # Aug 2019
		Rev # Initial
		Sheet # 1 of 1
		Draw # DCCR 1-00-1

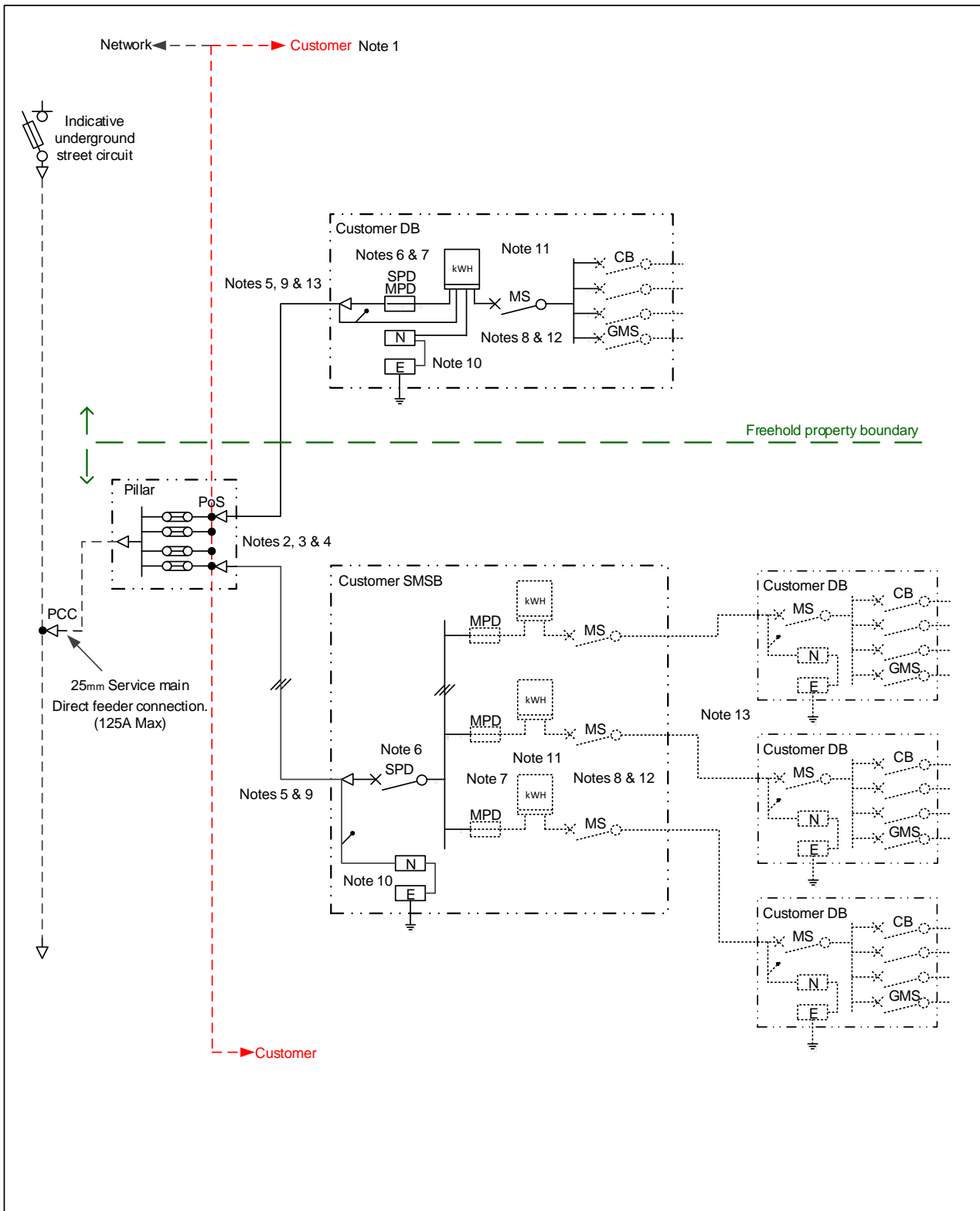

Drawings to be read in conjunction with applicable Guideline Notes

 Distribution Customer Connection Requirements EDM 43517326	Strata Connection Arrangements	Date # Sept 2019
		Rev # Initial
		Sheet # 1 of 3
		Draw # DCCR 1-01-10



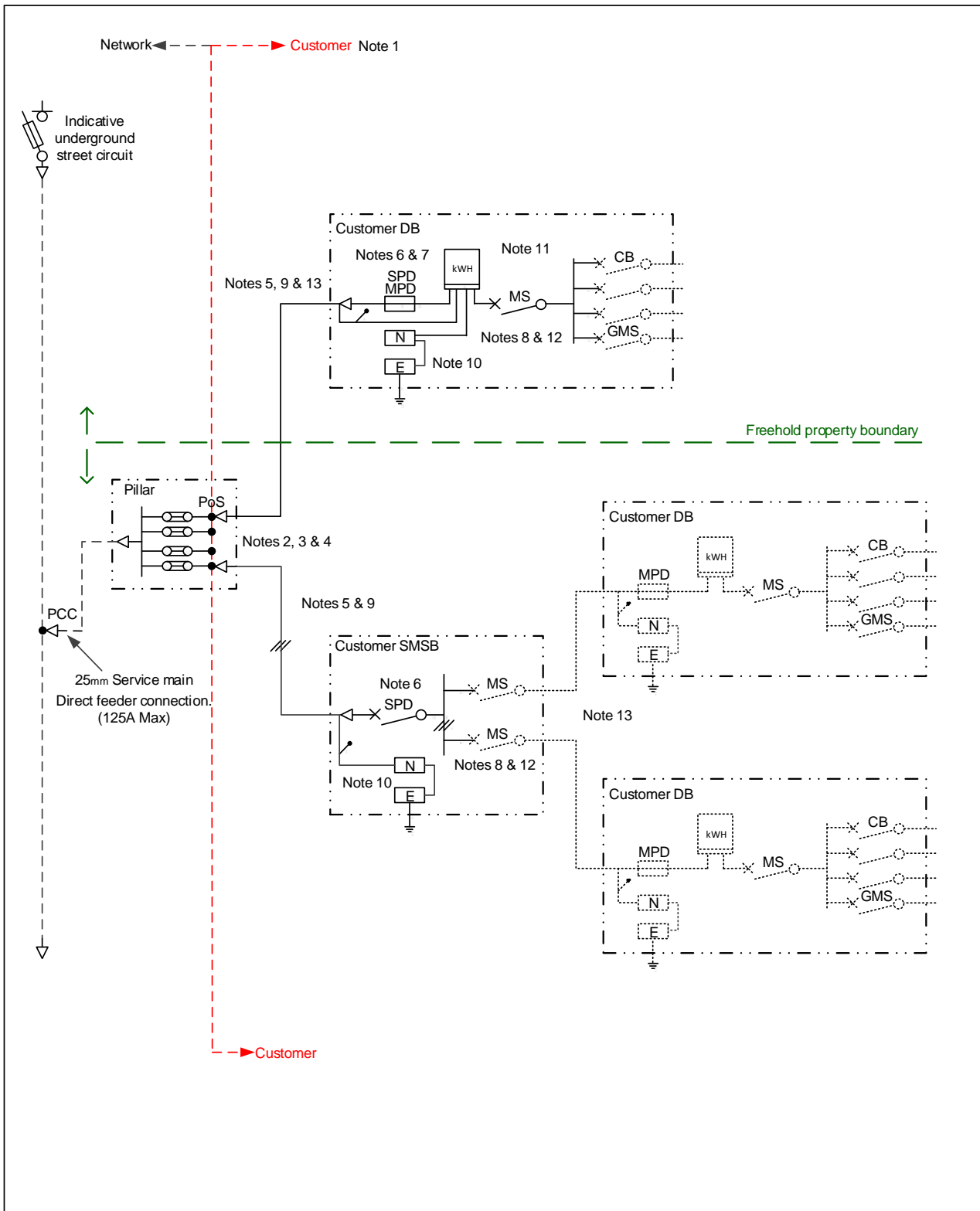

Drawings to be read in conjunction with applicable Guideline Notes

 westernpower Distribution Customer Connection Requirements EDM 43517326	Strata Connection Arrangements	Date # Sept 2019
		Rev # Initial
		Sheet # 2 of 3
		Draw # DCCR 1-01-10



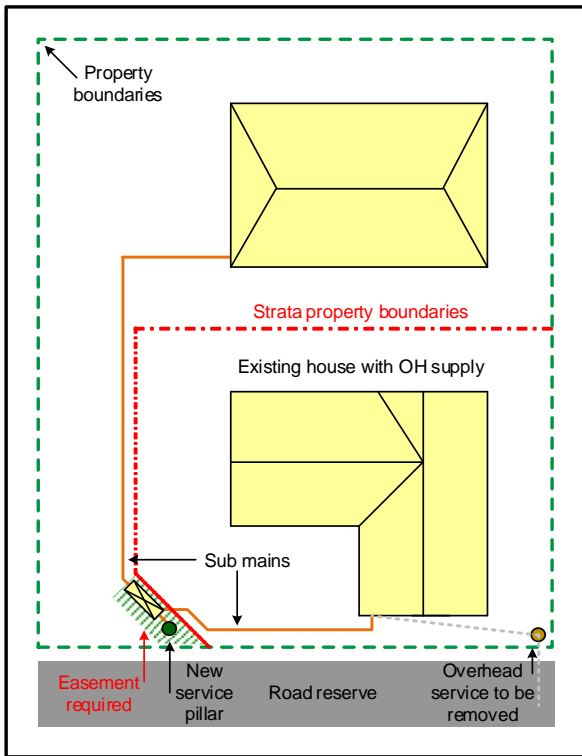
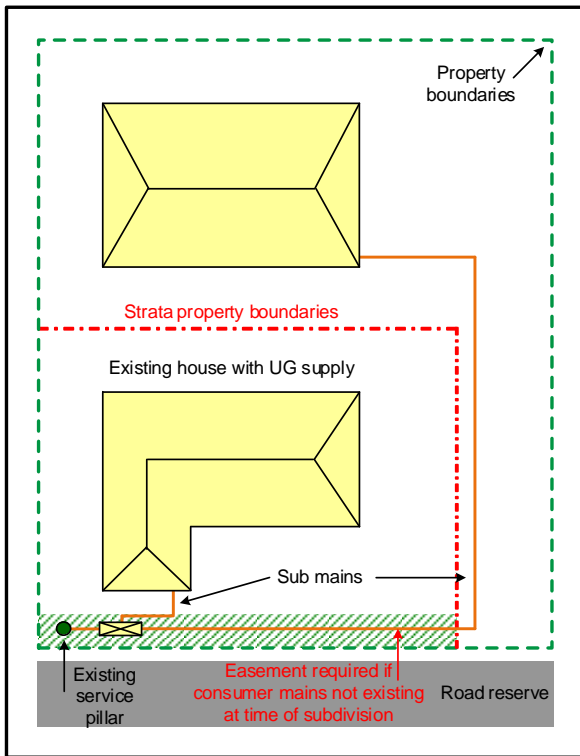

Examples are for illustration proposes only. May not be applicable in all cases.

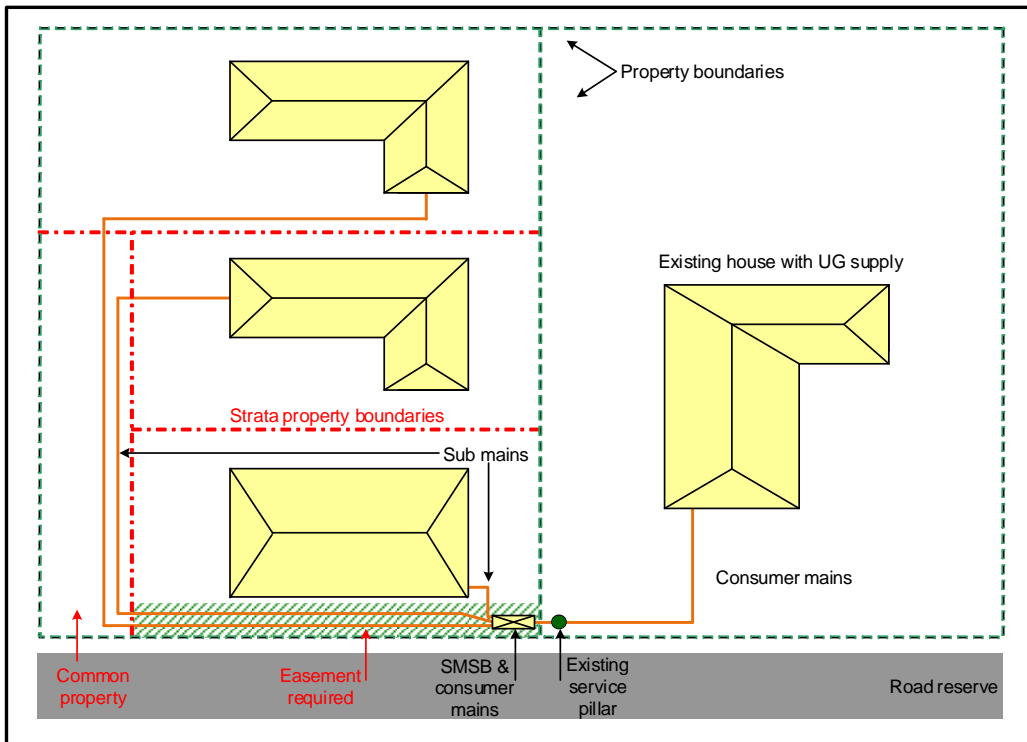

4.3 Exemption

For survey and built strata Subdivisions, a site main switchboard, to service the entire Subdivision, is required to be installed prior to clearance being granted.

An exemption to this clearance requirement may be sought where the applicant can demonstrate compliance with or provide Western Power with the following for all strata lots:

1. Builder site plans showing the permanent future position of the site main switchboard. The permanent position must be located within common property and not more than 30m from the Western Power point of connection/supply (i.e. pillar);
2. Current Building licences/Building Permits;
3. Date of commencement for the build on all properties;
4. Letter of intent from the Builder (signed and dated on a company letterhead) stating that on completion of the build, the site main switchboard containing all network meters will be installed in the nominated permanent position.
5. Formal confirmation that any existing overhead or underground electrical services to the Subdivision are or will be removed or converted to underground and connected to the MSB.

Note. If an electrical inspection is carried out and these terms and conditions have not been complied with further action may be initiated.

On receipt of the above, Western Power will assess the request for exemption and provide a formal response to the applicant. Should the request be approved, notification will be via return email with a copy of the approval forwarded to WA Electrical Inspectors office.

5. Dictionary

Words in the first column of the following table are defined terms and have the corresponding meaning shown in the second column of the table. Defined terms may appear in this document as capitalised.

Defined term	Meaning
Accountable	The staff member ultimately answerable for the correct and thorough completion of the objective or communication, and the one who delegates the work to those responsible. For example, an Accountable officer approves work that the responsible officer provides.
Connection Requirements	Western Australian Distribution Connections Manual (WADCM). This Manual defines Western Power's Distribution Connection Requirements inclusive of the standard "terms" and "phrases" used to describe these requirements.
Consumer mains	Those conductors between the network point of connection/supply and the customer's main switchboard. The conductors, are owned and maintained by the customer and form part of the customers' electrical installation.
Date of Publication	The date of approval shown in the "Approval History" located at the rear of this document.
Distribution network	South West Interconnected System – The transmission and distribution electricity network owned and operated by Western Power in the South West corner of Western Australia.

Defined term	Meaning
Dwelling (Standard)	Has the same meaning as that given by the Distribution Overhead to Underground Conversion Standard. (Seventh Edition)
Guideline	Statements or practices aimed at streamlining a particular business process according to a set routine or sound practice. Guidelines can be mandatory or optional.
Informed	Those staff members who are kept up-to-date on progress, often only on completion of communication and advice.
Metering installation	The devices and methods for the purpose of metrology as defined by the Metering Code 2012.
Meter	A Network operator owned device which measures and records electricity production or consumption.
Point of common coupling	The point on the network where the network connection assets associated with one or more points of connection/supply are coupled to primary network assets.
Point of connection/supply (Network)	The point (junction) at which the Network operators Distribution Network, connects to the customer owned assets or equipment serving the premises of the customer.
Network Operator	Western Power
Meter Protection Device (MPD)	<p>A fuse isolation and protection device located on the un-metered side of the network meter. The fuse, must have a base and carrier rating of 100 amps minimum, capable of accommodating a fuse cartridge with a maximum rating of 80 amps unless directed otherwise by the network operator.</p> <p>Note: The primary function of a MPD is to provide an authorised individual point of isolation, meter protection and to facilitate the safe replacement of metering equipment.</p> <p>The MPD does not replace the installation main switch and shall not be deemed as circuit protection for the customer's electrical installation, equipment, or circuitry.</p> <p>For a single customer service up to 80 amps, the service protection and meter protection devices can be the same physical device.</p>
Main switch (Based on AS/NZS 3000-1.4.82)	A switch, the primary function of which is the isolation of the connection/supply of electricity to the electrical installation. Where approved this device may also fulfil regulatory requirements provided it is labelled accordingly.
Service mains	Those network conductors between the network point of common coupling and the point of connection/supply.
Switchboard AS/NZS 3000-1.4.121	An assembly of circuit protective devices, with or without switchgear, instruments or connecting devices, suitably arranged and mounted for distribution to, and protection of, one or more submains or final sub-circuits, or a combination of both.
Switchboard, main AS/NZS 3000-1.4.122	A switchboard from which the supply to the whole electrical installation can be controlled.

Defined term	Meaning
Service protective device (SPD) (Based on AS/NZS 3000-1.4.106)	<p>A fuse or circuit-breaker installed as required by the network operator for interrupting the supply to and from the electrical installation on a consumer's premises from the supply main.</p> <p>Note: The primary function and purpose of a SPD is to provide:</p> <ul style="list-style-type: none"> • An authorised collective point of isolation of the customer's installation upstream of the metering installation; • Protection of the network operator's service equipment and mains; • Safe replacement of metering equipment where required (e.g. CT meter installations) <p>The SPD does not replace the installation main switch and shall not be deemed as protection for the customer's electrical installation, equipment, or consumer mains cable.</p>
Subdivision	<p>The division of a lot, tract, or parcel of land into two or more lots, sites, or other divisions of land for the purpose, whether immediate or future, of sale or of building development.</p> <p>Subdivision includes amalgamation.</p> <p>Refer Underground Distribution Schemes Manual (UDS)</p>

6. Content owner

The content owner is the Manager Distribution Grid Strategy (Grid Transformation)

7. Accountabilities

Western Power Operational Personnel,	Accountable for Standard and Guideline application and compliance.
Manager Distribution Grid Strategy	Accountable for the of review of distribution Standards and Guidelines
Senior Standards & Technology Officer Distribution Grid Strategy	Accountable for publishing the approved version of this Guideline.
Stakeholder Specialist Function/Area/Team	Accountable for Informing and circulating the published Guideline.

Any questions in relation to this Guideline should be referred, in the first instance to the relevant Operational Personnel, then either the Senior Standards & Technology Officer or Manager, Distribution Grid Strategy.

8. Review

The Guideline content will be used to review and where deemed appropriate update the relevant areas of the identified documents.

Where the Guideline is not incorporated into a subsequent document, the Guideline will be reviewed and evaluated by the content owner at least once in every three year period taking into account the purpose of the Guideline and the outcome of the compliance review.

9. Related documents

Title	EDM reference
AS/NZS 3000 -2018	Australian Standard
AS/NZS 4777 - 2016	Australian Standard
Overhead to Underground Conversion Standard (Previously known as - P2P)	DM 3081409
Application of Model Conditions	EDM 40420164
WA Electrical Requirements (WAER)	Building and Energy
Network Integrated Guideline. (NIG)	EDM 13753065
WA Distribution Connections Manual (WADCM) (PDF)	EDM 27130164
Underground Distribution Schemes Manual (UDS)	DM 3384127

10. Approval history

Version	Approved by	Date of approval	Notes
1.	Manager Distribution Grid Strategy	06-11-2019	Initial version (Refer to DCR for wet signatures)
2.	Manager Distribution Grid Strategy	24 01-2020	Inclusion of 2 lot strata requirements. (Refer to DCR for wet signatures).
3.			